

REVISION HISTORY			
REV	DESCRIPTION	DATE	APPROVED
0	RELEASE FOR PRODUCTION	12/13/07	

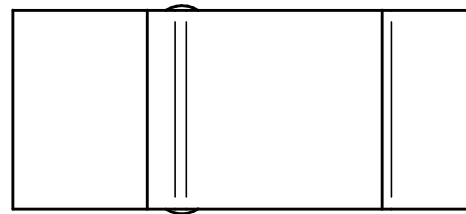

PIN
Ø0.187

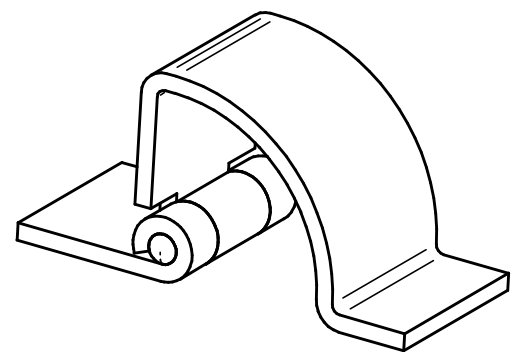

ISO VIEW

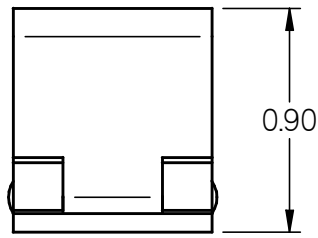

0.90

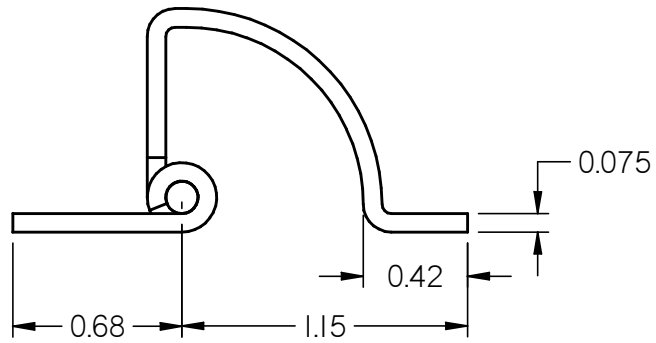

0.075

0.42

0.68

1.15

		NAME	DATE	
		DRAWN TOM	12/13/07	
CHECKED				
DWG NO	NCH-02-SS	REV	0	
TITLE CONCEALED HINGE				
<small>CE DOCUMENT AINSI QUE SON CONTENU SONT LA PROPRIETE DE QUICALLERIE INDUSTRIELLE NORMONT L.T.E.E. CE DOCUMENT CONTIENT DE L'INFORMATION CONFIDENTIELLE PROTEGEE EN DROIT. TOUTE REPRODUCTION, DISTRIBUTION, UTILISATION OU COMMUNICATION DE CE DOCUMENT OU DE SON CONTENU SANS CONSENTEMENT EXPRESS SONT STRICTEMENT INTERDITES.</small> <small>THIS DOCUMENT AND ITS CONTENTS ARE THE PROPERTY OF NORMONT INDUSTRIAL HARDWARE LTD. THIS DOCUMENT CONTAINS CONFIDENTIAL PROPRIETARY INFORMATION. THE REPRODUCTION, DISTRIBUTION, UTILISATION OR THE COMMUNICATION OF THIS DOCUMENT OR ANY PART THEREOF, WITHOUT EXPRESS AUTHORISATION IS STRICTLY FORBIDDEN.</small>		TOLERANCES	THIRD ANGLE PROJECTION	
REMOVE ALL BURRS & BREAK ALL SHARP EDGES	ALL DIMENSIONS ARE IN INCHES UNLESS OTHERWISE SPECIFIED	XX ±0.060 XXX ±0.030 XXXX ±0.015		SCALE N.T.S.
		ANGLES ±1.0° HOLES ±0.005		SIZE B
		SHEET 1 OF 1		

NOTES:

1. MATERIAL: TYPE 304 STAINLESS STEEL.
2. FINISH: 2B MILL
3. PIN RETENTION: SPUN ON BOTH ENDS.
4. SCALE: 2:1 (DO NOT SCALE)