

REVISION HISTORY			
REV	DESCRIPTION	DATE	APPROVED
0	FIRST RELEASE	01/21/08	

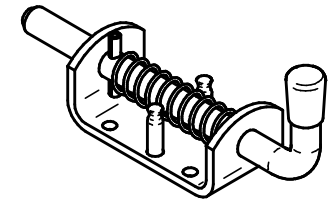

ISO VIEW

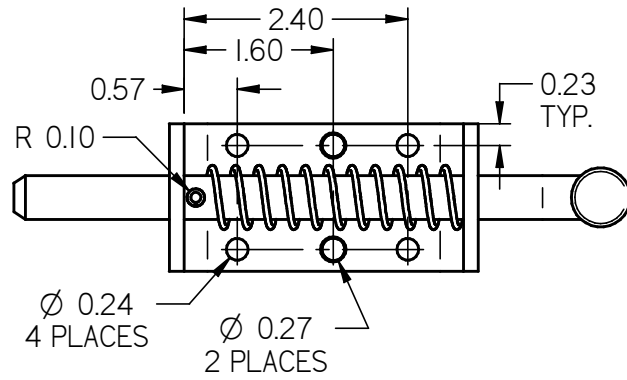
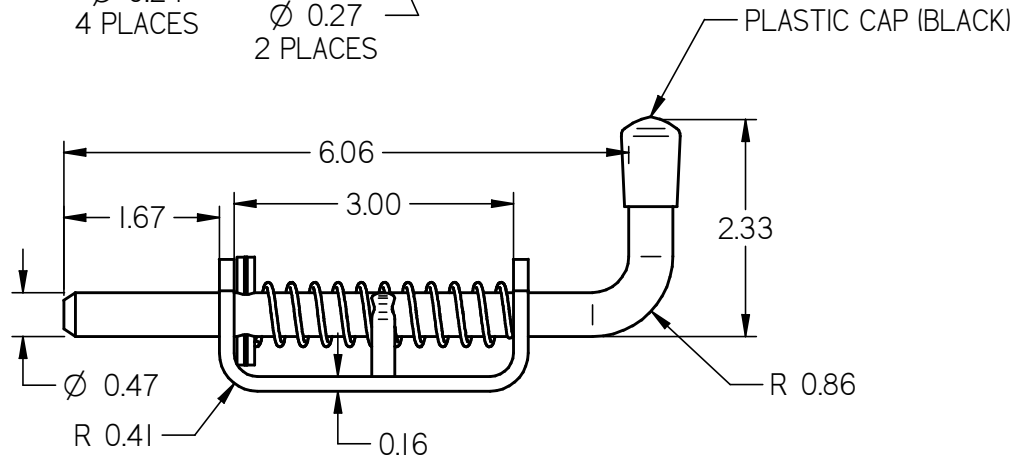
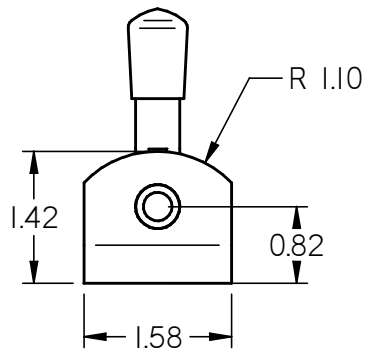

CE DOCUMENT AINSI QUE SON CONTENU SONT LA PROPRIETE DE QUICALLERIE INDUSTRIELLE NORMONT L.T.E.E.
 CE DOCUMENT CONTIENT DE L'INFORMATION CONFIDENTIELLE PROTEGEE EN DROIT. TOUTE REPRODUCTION, DISTRIBUTION, UTILISATION OU COMMUNICATION DE CE DOCUMENT OU DE SON CONTENU SANS CONSENTEMENT EXPRESS SONT STRICTEMENT INTERDITES.
 THIS DOCUMENT AND ITS CONTENTS ARE THE PROPERTY OF NORMONT INDUSTRIAL HARDWARE LTD.
 THIS DOCUMENT CONTAINS CONFIDENTIAL PROPRIETARY INFORMATION. THE REPRODUCTION, DISTRIBUTION, UTILISATION OR THE COMMUNICATION OF THIS DOCUMENT OR ANY PART THEREOF, WITHOUT EXPRESS AUTHORIZATION IS STRICTLY FORBIDDEN.

REMOVE ALL
BURRS & BREAK
ALL SHARP
EDGES

ALL DIMENSIONS ARE IN
INCHES
UNLESS OTHERWISE SPECIFIED

	NAME	DATE	
DRAWN	TOM	01/21/08	
CHECKED			
DWG NO	NTL-1	REV	0
TITLE	SPRING BOLT		
TOLERANCES	THIRD ANGLE PROJECTION	SCALE	N.T.S.
XX ±0.060		SIZE	B
XXX ±0.030			
XXXX ±0.015			
ANGLES ±1.0°			
HOLES ±0.005			
		SHEET 1 OF 1	

NOTES:
 1- MATERIAL: MILD STEEL
 2- FINISH: CLEAR ZINC PLATING